



MARINE COMPACT LED LANTERN

MCL 250



The MCL 250 is a compact LED marine lantern of medium range, with built-in solar power, characterized by great optical efficiency and low consumption, made up of LED diodes of high intensity, reaching a maximum range of 11 nautical miles. Especially suited to locations where the solar radiation level is reduced.

Its luminous source consists of an innovating lens system especially designed to take the maximum profit of LED diodes, thus obtaining an output of up to 180 Cd/W.

Ideal for medium-range beaconing applications requiring a low consumption, on- and off-shore, such as channels, river mouths, piers, buoys, marine structures, etc. Manufactured with high-quality and resistant materials, the MCL 250 provides a long service life under harsh marine conditions.

Designed according to IALA Recommendations.

FEATURES

- ✓ High-efficiency luminous system.
Up to 8 nm (T=0.74), 11 nm (T=0.85).
- ✓ Vertical divergence up to 30° (MCL 250-HD).
- ✓ 360° horizontal output.
- ✓ Average operation lifetime over 10 years.
- ✓ IP 67 watertightness degree (immersion resistant).
- ✓ Double RS-232 serial port for setting adjustments by PC and remote monitoring system.
- ✓ Programming, configuration and operating status via PC, IR programmer or Bluetooth as an option.
- ✓ Ready to integrate remote monitoring via GSM, VHF or satellite, and synchronization module via GPS.
- ✓ Autonomy without solar charging up to 700 hours.
- ✓ Automatic energy management, according to latitude.
- ✓ 4 nos. solar modules of 7.5W each.
- ✓ **PATENTED OPTICAL SYSTEM.**



MARINE COMPACT LED LANTERN

MCL 250



Specifications subject to change without previous notice. Luminous ranges will be affected depending on latitude, flash rhythms and chosen options.

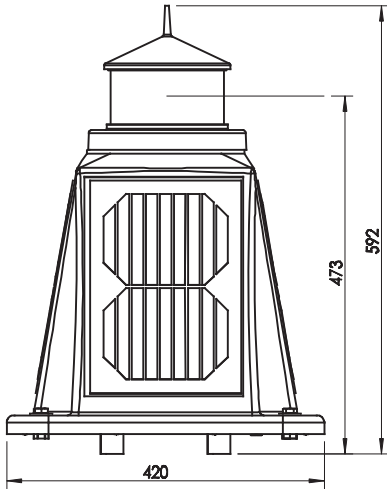

MCL 250 with 12° vertical divergence.

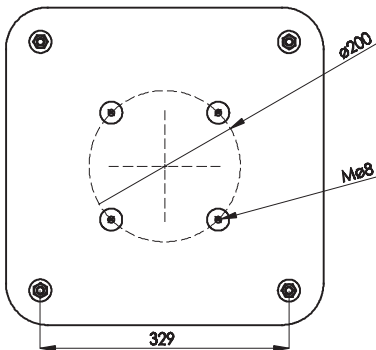

Options

- Infrared (IR) programmer.
- PC programming kit.
- Bluetooth programming.
- Fixing kit for 3 bolts in a 200mm diameter.
- 40 Ah battery.
- Other specifications available under request.
- MCL 250-HD (with divergence up to 30°).
- MCL 250-SYNC (GPS synchronization).
- MCL 250-TG (GSM remote monitoring).
- MCL 250-TR (Radio remote monitoring).
- MCL 250-TS (Satellite remote monitoring).

Optical System

Light source:	3 to 6 nos. ultra-bright LED diodes, with high-precision acrylic lens.
Luminous range:	Up to 8 nm (T=0.74) 11 nm (T=0.85).
Colours available:	White, green, red, amber and blue.
Vertical divergence:	From 5° to 30° (50% lo).
LED average life:	More than 100,000 hours.

Electronic control

Flash rhythms:	256 (6 nos. user selectable).
Day/night threshold:	Adjustable in lux.
Solar charge regulation function:	Regulation in 3 phases.
Settings:	PC / IR programmer (optional Bluetooth).
Energy management:	Dynamic, according to latitude.
Light intensity reduction due to low battery:	Configurable by the user.

Solar modules and battery

Solar modules:	4 nos of 7.5W each.
Battery:	32 Ah, gelled, maintenance-free (optional battery of 40 Ah).
Autonomy without solar charging:	Up to 700 hours.

Materials and environment

Base:	Reinforced polyamide and rotomoulded polyethylene.
Lens cover:	Acrylic, UV stabilised.
Vibration resistance:	MIL-STD-202G, Method 204D (5G).
Shock resistance:	MIL-STD-202G, Method 213B.
Watertightness degree:	IP 67.
Fixings:	Internal of 4 bolts in a 200mm diameter / External of 4 bolts in a 465mm diameter.
Humidity resistance:	100%. Pressure-compensation valve to avoid condensation.
Temperature range:	From -20° to 70°C.
Inside hardware:	Stainless steel.

MCL 250	PEAK INTENSITIES (Cd)	
	VERTICAL DIVERGENCE 5°	VERTICAL DIVERGENCE 12°
White	436	228
Green	350	218
Red	284	154
Amber	321	171

Other divergences available.



MEDITERRÁNEO SEÑALES MARÍTIMAS, S.L.L.
mesemar@mesemar.com • www.mesemar.com

